

The  
**AMSAT**®  
Journal

*Editor-in-Chief*  
Joe Kornowski, KB6IGK

*Assistant Editors*  
Bernhard Jatzeck, VA6BMJ  
Douglas Quagliana, KA2UPW/5  
Paul Graveline, K1YUB

Volume 45, Number 4

July/August 2022



**CubeSatSims  
Really Taking Off**

*In this issue —*

Apogee View..... 3  
by Robert Bankston • KE4AL

Educational Relations Update...4  
by Alan Johnston • KU2Y

My First Simulated Satellite ..... 5  
by Virginia Smith • NV5F

Building AMSAT CubeSatSims in  
the Classroom..... 9  
by Alan Johnston • KU2Y and  
Edward Char

2022 AMSAT Field Day  
Results ..... 21  
by Bruce Paige • KK5DO



**Field Day Results**



# From portable handheld antennas to command/control arrays, M2 Antenna Systems can supply what you need.

WORLD CLASS PRODUCTS



Are you ready for Fox 1C & 1D? Missing out on all the action on the latest birds? The M2 LEO-Pack is a great solution for LEO communication. You do not need an elevation rotator for casual operation, but elevation will allow full gain over the entire pass.

The 2MCP8A is a circularly polarized antenna optimized for the 2M satellite band. The 436CP16 has been designed for an optimum match and gain at the 70CM satellite band. A perfect system for a small home or portable system.

\*See our review, QST March 2016 page 60.

Need a bit more link margin? The 2MCP14, 2MCP22, 436CP30, 436CP42 antennas are HEO capable. Optional items are also available like the CB60 fiberglass cross boom, power dividers, polarity switches, phasing lines and complete H-Frame assemblies.



M<sup>2</sup> offers a complete line of top quality amateur, commercial and military grade antennas, positioners and accessories.

We produce the finest off-the-shelf and custom radio frequency products available anywhere.

For high frequency, VHF, UHF and microwave, we are your source for high performance RF needs.

M<sup>2</sup> also offers a diverse range of heavy duty, high accuracy antenna positioning systems.

Whether your communication requirements are across town, around the world or beyond, M<sup>2</sup> has World Class Products to suit your application.

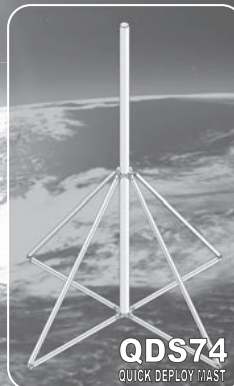

M<sup>2</sup> products are proudly 'Made in the USA'

4402 N. Selland Ave.  
Fresno, CA 93722  
Phone (559) 432-8873  
sales@m2inc.com  
<http://www.m2inc.com>

\*Prices subject to change without notice.

**ANTENNAS POSITIONERS ACCESSORIES**

## Write for The AMSAT Journal

The AMSAT Journal is looking for interesting articles, experiences and photos to share with other AMSAT members. Writing for the Journal is an excellent way both to give back to the AMSAT community and to help others learn and grow in this most fascinating aspect of the amateur radio avocation.

Find a quiet place, sit yourself down, get out your laptop or pick up a pen, and ...

1. Launch your inner writer;
2. Downlink your knowledge and experiences to others by:
  - Sharing your adventures in the "On the Grids" column or
  - Describing your AMSAT career in "Member Footprints;"
3. Transmit lessons learned from operational and technical projects;
4. Log some of your more interesting passes across the sky; and
5. Boost others to a higher orbit of know-how and experience.

After your article lands in members' mailboxes, and the kudos start arriving for your narrative payload, you can enjoy the satisfaction of knowing you've elevated the collective wisdom of AMSAT to a higher trajectory. Send your manuscripts and photos, or story ideas, to: [journal@amsat.org](mailto:journal@amsat.org).

Our editors are standing by!

### AMSAT's Mission

AMSAT is a non-profit volunteer organization which designs, builds and operates experimental satellites and promotes space education. We work in partnership with government, industry, educational institutions and fellow Amateur Radio societies. We encourage technical and scientific innovation, and promote the training and development of skilled satellite and ground system designers and operators.

### AMSAT's Vision

Our Vision is to deploy satellite systems with the goal of providing wide-area and continuous coverage. AMSAT will continue active participation in human space missions and support a stream of LEO satellites developed in cooperation with the educational community and other amateur satellite groups.



**The AMSAT Journal Staff**

Editor-in-Chief: Joe Kornowski, KB6IGK,  
kb6igk@amsat.org  
Assistant Editors:  
Douglas Quagliana, KA2UPW/5  
Bernhard Jatzek, VA6BMJ  
Paul Graveline, K1YUB

**AMSAT Board of Directors**

Jerry Buxton, N0JY, n0jy@amsat.org  
Drew Glasbrenner, KO4MA, ko4ma@amsat.org  
Mark Hammond, N8MH, n8mh@amsat.org  
Bruce Paige, KK5DO, kk5do@amsat.org  
Joseph Armbruster, KJ4JIO, kj4jio@amsat.org  
Robert Bankston, KE4AL, ke4al@amsat.org  
Paul Stoetzer, N8HM, n8hm@amsat.org  
Zach Metzinger, N0ZGO, n0zgo@amsat.org

**AMSAT Senior Officers**

President: Robert Bankston, KE4AL  
Executive Vice President: Paul Stoetzer, N8HM  
Treasurer: Steve Belter, N9IP  
Secretary: TBD  
Vice President, Engineering: Jerry Buxton, N0JY  
Vice President, Operations: Drew Glasbrenner, KO4MA  
Vice President, User Services: TBD  
Vice President, Educational Relations: Alan B. Johnston,  
KU2Y  
Vice President, Development: Frank Karnauskas, N1UW

**Honorary Positions**

Immediate Past President: Clayton Coleman, W5PFG  
Founding President: Perry Klein, W3PK

**Editorial Office: Joe Kornowski KB6IGK, 3310 W. Braker Ln., Suite 300-322, Austin, TX 78758. Please e-mail Journal submissions to: [journal@amsat.org](mailto:journal@amsat.org).**

*The AMSAT Journal* (ISSN: 1407-3076) is published bi-monthly (Jan/Feb, Mar/Apr, May/June, Jul/Aug, Sep/Oct, Nov/Dec) by AMSAT.

Opinions expressed in *The AMSAT Journal* are those of the article authors and are not necessarily those of AMSAT. Copyright ©2021 by AMSAT, The Radio Amateur Satellite Corporation. AMSAT is a registered trademark. Reproduction of material from *The AMSAT Journal* by mechanical, electronic, photocopy or other means is prohibited unless written permission is obtained from *The AMSAT Journal* and the author.

**The AMSAT Journal staff is always interested in article submissions. Whenever possible, submissions should be sent via e-mail to [journal@amsat.org](mailto:journal@amsat.org) using plain text or word processor files; photos or figures in TIF, GIF or JPG formats. Kindly do not embed graphics or photos in your manuscript. We prefer receiving those as separate files. AMSAT reserves the right to select material for *The AMSAT Journal* based on suitability of content and space considerations.**



# Apogee View

## Robert Bankston, KE4AL President



In this "Apogee View," I want to highlight two important topics: this year's AMSAT Symposium; and volunteers' significant role in AMSAT's accomplishments.

### AMSAT Symposium

Three years after we were last able to get together in person at an AMSAT Symposium, I feel excited for the opportunity to meet up in Minnesota next month.

AMSAT symposia are not only an excellent opportunity to celebrate amateur radio in space and share what everyone is working on, but they also provide us with unique opportunities to formulate new directions, ideas, and projects. Some of AMSAT's most innovative accomplishments started with a discussion that began at a symposium. I hope that you can attend and be part of this experience.

The 40th AMSAT Space Symposium and Annual General Meeting will be held on Friday through Saturday, October 21-22, 2022, in Bloomington, Minnesota.

Highlights of all scheduled events include:

- AMSAT Board of Directors Meeting, October 20-21
- 40th AMSAT Space Symposium and Annual General Meeting, October 21-22
- Friday Night Social and Auction, October 21
- AMSAT Banquet and Reception, October 22
- AMSAT Ambassador Breakfast, October 23

The 40th AMSAT Space Symposium is open to anyone interested in advancing the art and science of amateur radio in space. To register, please visit <https://launch.amsat.org/Events>. Crowne Plaza is located adjacent to the Minneapolis / St. Paul International Airport and provides a complimentary, scheduled shuttle to and from the airport. Nearby attractions include Mall of America, Target Field, Minnesota Zoo, and the Nickelodeon Universe theme park.

You can make reservations by calling the hotel at (952) 854-9000. The group code is ASG (Amateur Satellite Group). Alternatively, you can make reservations online at:

[www.crowneplaza.com/redirect?path=asearch&brandCode=CP&localeCode=en&ionCode=1&hotelCode=mspia&checkInDate=19&checkInMonthYear=092022&checkOutDate=23&checkOutMonthYear=092022&rateCode=6CBARC&PMID=99801505&GPC=ASG&cn=no&viewfullsite=true](http://www.crowneplaza.com/redirect?path=asearch&brandCode=CP&localeCode=en&ionCode=1&hotelCode=mspia&checkInDate=19&checkInMonthYear=092022&checkOutDate=23&checkOutMonthYear=092022&rateCode=6CBARC&PMID=99801505&GPC=ASG&cn=no&viewfullsite=true).

### We are AMSAT

Conversations on the AMSAT Bulletin Board start with "AMSAT should..." or "AMSAT needs to...." While these often express great suggestions, the proposals quickly fade into the ether when proponents are asked if they are volunteering.

Asking if someone is volunteering is not meant to slight anyone in any way or discount their ideas; rather, it is a product of who we are and where we are.

AMSAT is an all-volunteer membership organization, and, as such, it draws its strength and accomplishments from its membership. Out of 4,000 members, AMSAT currently has approximately 40 core volunteer engineers, builders, programmers, educators and administrators, who are all fully engaged with the current projects. Thus, taking on any additional work requires additional volunteers.

Think about this for a minute: 40 volunteers out of 4,000 members represent only one percent of our membership. Since we have already achieved so much with that one percent, how much more could we accomplish if we had more of our members volunteer? The potential to advance the art of radio science in space and reach farther is unlimited. Please help us get there!

If you are ready to answer the call, please get in touch with me at [rbankston@amsat.org](mailto:rbankston@amsat.org). Until next time, Onward & Upward! 🌍



## Educational Relations Update

**Alan Johnston, Ph.D., KU2Y**  
**V.P. Educational Relations**

This month's *Journal* includes an article about how we built six CubeSatSims in a classroom setting at Villanova University this spring. The description of how we broke the students into small groups focused on a subsystem of the CubeSatSim could be helpful to anyone planning to do a group build. As always, your feedback and comments are most welcome.

Supply chain issues are disrupting the electronics industry, which has also affected us at AMSAT. AMSAT VP of Engineering, Jerry Buxton, N0JY, has faced numerous challenges in designing and building our GOLF CubeSats. In the CubeSatSim project, we have had issues as well. Sometimes, it has just been certain parts becoming unavailable or the price rising and quality deteriorating. For instance, the purple INA219 boards we use to measure voltage and current on the solar panels, battery, and main bus did all three of those. We since have switched to the blue INA219 boards, although they are slightly larger, and you need to mount them on sockets or pin headers to make them fit.

A bigger problem, however, has been the difficulty in obtaining the Raspberry Pi Zero single board computers that run the CubeSatSim software. As a result, we have developed a version of the CubeSatSim that runs on a Raspberry Pi Pico, an RP2040-based microcontroller that is cheap (\$4) and in good supply. A beta version of the CubeSatSim Pico will be available soon! You can find more information at [github.com/alanbjohnston/CubeSatSim/wiki/CubeSatSim-Pico](https://github.com/alanbjohnston/CubeSatSim/wiki/CubeSatSim-Pico).

I greatly enjoy hearing from others about their CubeSatSim projects. About a year ago, I contacted Virginia Smith, NV5F, who is taking electrical engineering classes at American Public University. I was introduced to her via email by Tom Schuessler, N5HYP, who has coordinated AMSAT's Moon Day table at the Museum of Flight in Dallas, TX, and has borrowed a CubeSatSim Loaner for the event. Virginia was interested in aerospace communication and saw building a CubeSatSim as a way to gain hands-on experience and learn more about space communications.

Since then, she has emailed me about her

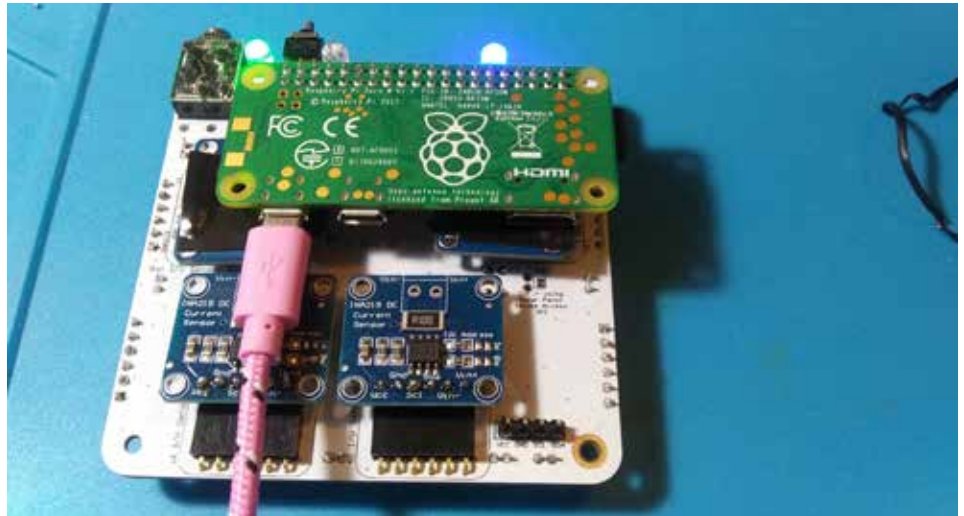

**Figure 1 — CubeSatSim built by Virginia Smith, NV5F. Photo courtesy of Virginia Smith.**

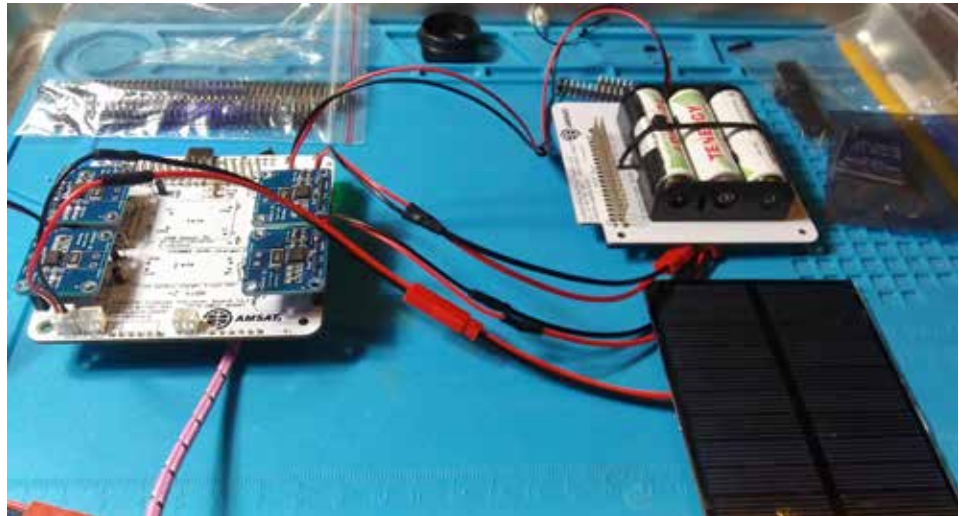

**Figure 2 — CubeSatSim in Flat Sat testing. Photo courtesy of Virginia Smith.**



**Figure 3 — CubeSatSim at the Moon Day 2022 event at the Frontiers of Flight Museum in Dallas, TX. Photo courtesy of Virginia Smith.**

progress on the project. As a first-time Raspberry Pi user, she initially had some difficulty logging into her Pi but eventually got the correct adapter cables and was able to access them. She sent some photos of her preliminary testing. As you can see in the photos, she had some help!

She indicated that she likes the build videos in which I film myself building a CubeSatSim [youtube.com/playlist?list=PL-pgyk1pc4\\_MzuEISC6wYTKJu4z9UWvrx](https://www.youtube.com/playlist?list=PL-pgyk1pc4_MzuEISC6wYTKJu4z9UWvrx).

She also had problems with the purple INA219 boards that measure current and voltage of the solar panels, battery, and 5V regulator. She eventually switched to the blue INA219 boards and got them working. Her goal was to finish the build by the Moon Day 2022 event to show it off. Unfortunately, she didn't quite get everything completed by the event, but she showed off her CubeSatSim "FlatSat" at the AMSAT table.

Virginia has also been sharing her results and enthusiasm for the project on the CubeSatSim Discussions board on Github: [github.com/alanjohnston/CubeSatSim/discussions](https://github.com/alanjohnston/CubeSatSim/discussions).

You can read about all of Virginia's adventures in her article, "My First Simulated Satellite" in this issue. It is very well written and gives you a real feel for what it is like to build a CubeSatSim.

If you have a Hamfest or STEM or Maker event in your area coming up, why not borrow a CubeSatSim Loaner and show it off? Contact me via email at [ku2y@arrl.net](mailto:ku2y@arrl.net) or on Twitter [@alanjohnston](https://twitter.com/alanjohnston) to make the arrangements.

For the latest CubeSat Simulator news, follow our dedicated Twitter account [@CubeSatSim](https://twitter.com/CubeSatSim). 🌐



## My First Simulated Satellite (How I Learned to Stop Worrying and Love Digikey)

Virginia Smith, NV5F

When I decided to build an AMSAT Cubesat Simulator last summer (2021), it was like when I had decided to build Bob Heil's Pine Board Project (AM phone tube transmitter) in 2017. I scarcely imagined how many parts I would have to get, how much time it would take to build, how much I would learn when things didn't go exactly according to plan, or how practical an experience it would be for someone beginning electrical engineering studies. Nevertheless, with high hopes, I ordered the Cubesat Sim version 1.0 printed circuit boards from AMSAT as soon as I heard they went on sale and vowed to build this thing!

Since then, two friends from my amateur radio club (Arlington ARC in Arlington, Texas) have also expressed an interest in the project. I strongly encourage getting some assistance because this is an ambitious project, and there is safety in numbers, not to mention that many parts can not be bought individually. It's also a great way to pool resources.

I have recently assisted in designing a few simple amateur radio kits. Still, I'd never dealt with a bill of materials (BOM) on quite this scale. Even with Alan Johnston's wonderfully exhaustive and detailed online construction manual, I still found the gaps in my knowledge and experience daunting. I realized how much is apparently second nature to many of today's code-savvy, 3-D printing-friendly maker crowd. On this front, having had one computer programming course a couple of years ago did aid me in getting through the detailed business of setting up and grabbing code for the Cubesat Sim microcontroller. Additionally, a generous friend with a 3-D printer can be gold!

I could never hope to write a succinct description of my complete experience. However, I'd like to share some of the things I took away from the process of building a Cubesat Simulator from the perspective of someone who is still relatively new to all this, including satellites in general. As always, I will make my account and accompanying

advice as much fun as possible and take care to acknowledge those who helped me out on the journey. I desire to encourage other potential satellite builders and ease their way as best I can.

When I began the endeavor, a friend helped me out by ordering the parts for the main board only on my behalf, with the fair assumption that one could build the sim as a peace-meal effort. However, one of the first things I discovered is that you can't build this thing one board at a time. The building process is like solving Rubik's Cube: it can seem like disjointed chaos until the magic moment when everything comes together at the end.

The nature of the carefully ordered building and testing process means that the main board is built and tested in stages, interspersed with other tasks involving testing hardware, setting up software, or building part of another board. Though I suggest trying to get the complete BOM at one time, one advantage of waiting on parts now and then was that I could not get too impatient or anxious to finish, and the breaks between sections helped me keep my head clear. This can help a less experienced technician avoid getting in a rush, making mistakes caused by overconfidence, or simply being in a hurry. I still made my share of errors! And I had some excellent help fixing them.

Studies, life, and some frustration with getting a Raspberry Pi to talk to a PC got in the way during the fall and winter of 2021/2022, and this little satellite fell off my radar for a while. Then, in the spring of this year, I felt up to it again and decided to make another go at it. I solved the problem of getting a PC to be a terminal for a Raspberry Pi by leaving the PC out and buying some adapters that would allow me to connect a monitor and a keyboard directly. Sometimes it takes me a while to realize that spending a few dollars can save time and that the extra expense can be worth it. So, I ordered the remaining parts from the BOM and began again in earnest.

This time around, I discovered that over the last year, things had become harder to come by and more expensive. As I got back underway, I would periodically find this or that part was missing or that I had ordered the wrong thing. My little bit of previous experience sourcing parts for a couple of small kits did come in handy, in addition to the BOM for this project being thorough in the source information. Now and then, I had to search for a part where the link had changed, or the part was out of stock. These



days sources need to be updated constantly as supplies deplete rapidly and prices frequently change, especially if a neat project comes along and creates a run on specific parts! So, even when the BOM is excellent, expect to do a little searching. At times I found myself combing the internet and digging deep into the big supplier sites. It was a perfect low-pressure opportunity to get to know the likes of Digikey, Adafruit and Ali-Express better than before. Amazon also proved an excellent resource for obscure parts.

As I revisited the Cubesat Sim in the spring and continued my build, I found the computer stuff, like setting up SDR# and Foxtel and remembering conventions of a UNIX shell, just as challenging as building and testing the sim. However, I took my time with construction and setup and gradually felt more accomplished until the day of the great sensor debacle.

So, in the gap between the summer of 2021 and spring of 2022, a new version of the Cubesatsim PCBs was released. One beneficial update was a place for a test header to deal with the issue that many of the small purple INA219 voltage/current sensor boards were turning up bad (likely due to a quality control issue). Eight of them are on the simulator's main board to monitor the voltage on the power supply, the batteries, and the six solar panels which recharge the batteries. I noticed in the build manual that there was an option to install these sensors with or without sockets, and since I was unaware of the issue with their quality, I installed them directly onto the board with the supplied pin headers.

Unfortunately, when it came time to test them, I got all kinds of inconsistent results, and soon my confidence was replaced by frustration. At least half of the INA219 sensors were not functioning as expected, and the harder I tried to fix things by reheating solder and troubleshooting, the worse it seemed to get. Finally, my friend Rob May, W5WS, an expert in building and fixing things, came to my rescue but was also stumped and found that forcibly removing the three or four bad sensors from the main board would likely do some damage.

Project director Alan Johnston kindly helped supply me with a new version 1.2 main board, and I ordered more sensors. Alan recommended that I get the more ubiquitous sensors since they have become more reliable. Getting them to fit neatly would be a challenge, but this is real engineering! Another story, which is too long to tell here, is how I ended up with a mess of the little

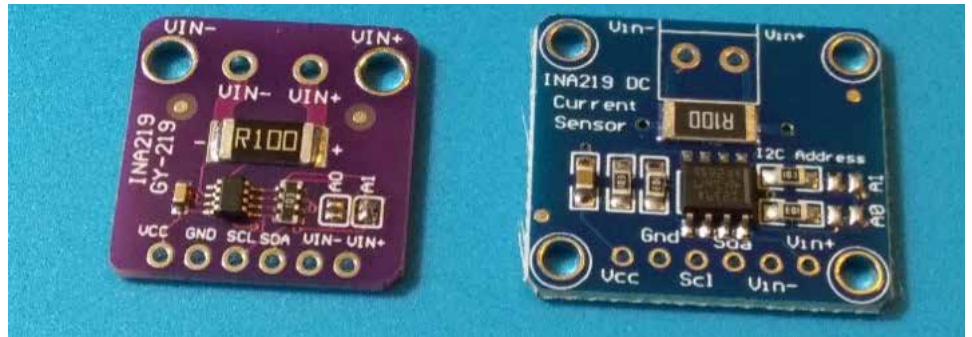

Figure 1 — INA219 sensor boards. On the left is the smaller purple board. On the right is the larger blue board. (All photos courtesy of Virginia Smith, NV5F.)

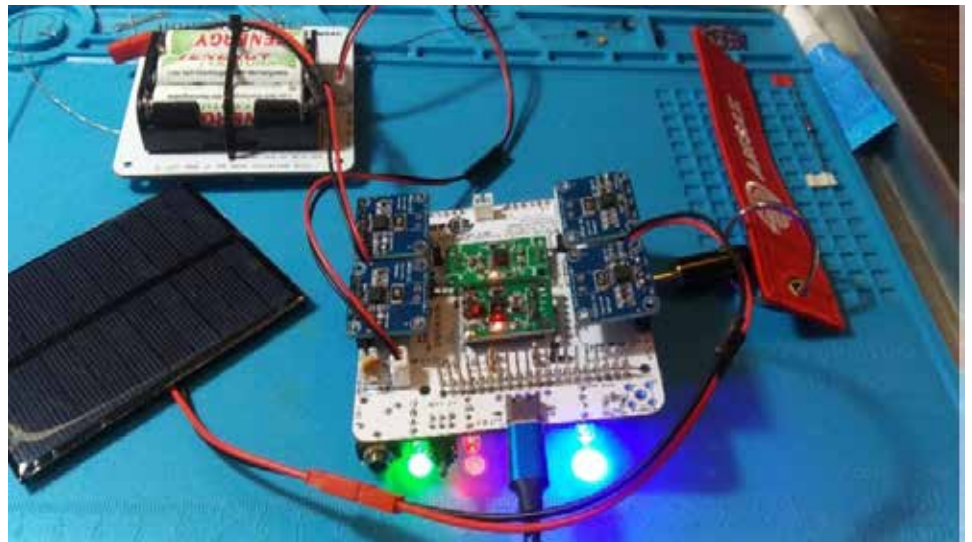

Figure 2 — Blue INA219 sensors installed in sockets on the Simulator main board.

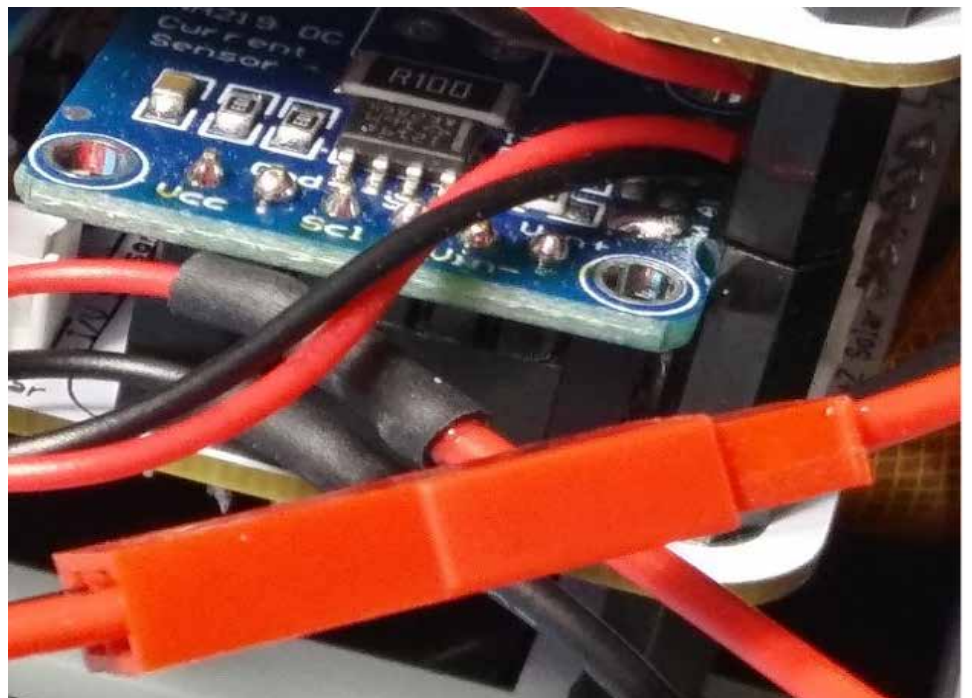

Figure 3 — Making a small notch in the edge of the INA219 sensor with a Dremel tool allows it to fit up against the standoff. Thanks to Mike McPherson, KQ9P, for this simple solution.

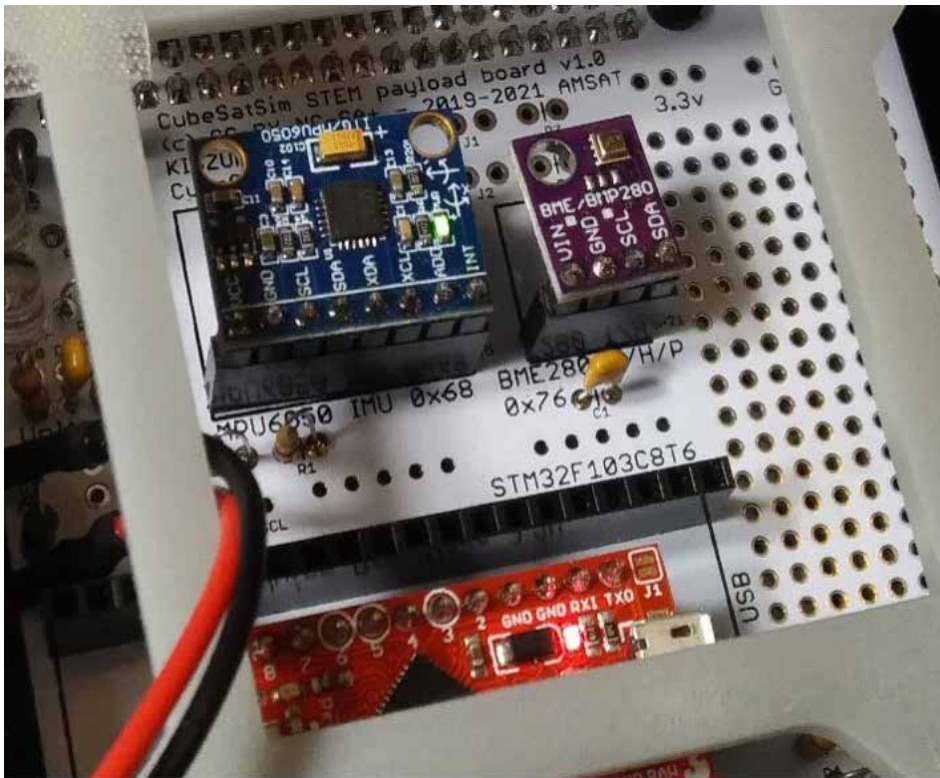

Figure 4 — Sensors in the sockets on the Cubesat Sim payload board

purple sensors but decided to go with the blue ones to be safe. Though I did not relish the idea of practically starting over, I did so carefully and with some replacement parts from Rob, who had also decided to build a sim and had ordered some duplicates for me when buying his own parts. In my second attempt, I used a combination of right-angle sockets and regular tall headers and found the test header on the main board version 1.2 to be invaluable. And – wouldn't you know – all the spare purple sensors I had ordered tested good! I still decided to go with the blue ones and found my combination of sockets entirely satisfactory, albeit a little tightly spaced. I took a construction tip from Mike McPherson, KQ9P, on the GitHub Cubesat Simulator project discussion board and notched the edges of a couple of the sensors with a Dremel tool so they would clear the standoffs used to stack the boards in the final construction. I also enjoyed the peace of mind that a bad sensor can be easily replaced anytime.

Before installing the sensors on the main board, builders set up the ground station with Foxtelam and use this to test them with the test header on the board and then

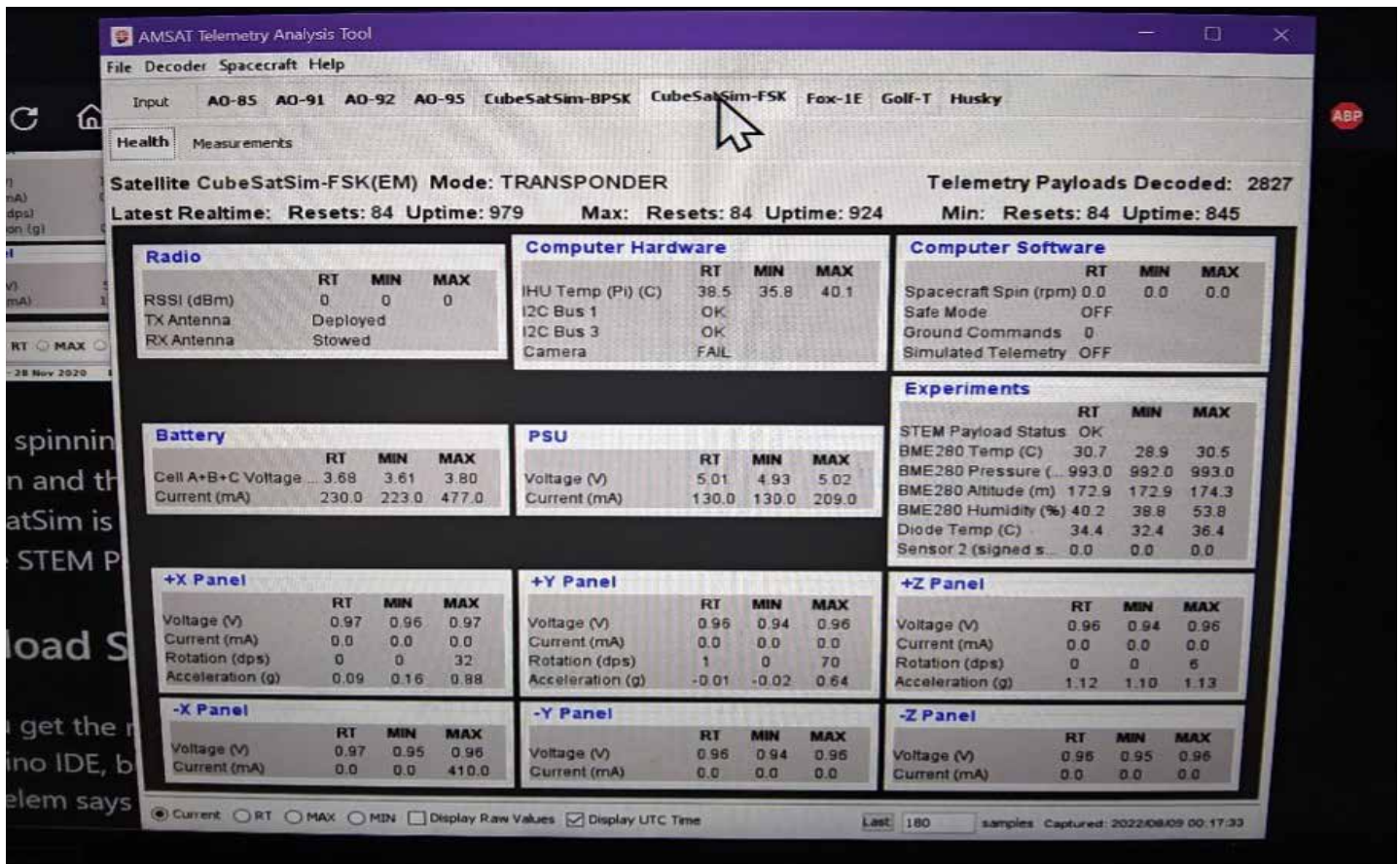

Figure 5 — Testing sensors with Foxtelam: battery and power supply voltage show normal; experiments tab shows telemetry from the environmental sensor on the payload board; lower half of the screen is telemetry from the six solar panels, which are disconnected.





Figure 6 — +Y side of the sim with the Pi camera installed: the small solar panels had a slightly different configuration of the power contacts than the ones on the BOM, so connecting them in parallel left a wire or two showing.

to test them again, one at a time, as they are installed. Though this process slowed things down, it kept me patient and clear-headed, and I knew if something failed, I'd be very sure of what it was and why it wasn't working. Setting up the ground station should be moved up in the order in the construction manual for this very reason. I will also encourage Cubesat Simulator builders to join the project at [github.com](https://github.com). It is a chance to find knowledge, encouragement, updates, and advice from others working on the project.

And for those less initiated in Arduino-based microcontrollers, I will recommend the Sparkfun Pro Micro as the controller of choice. I started with an STM32 "Blue Pill," but I found the setup long and daunting. With the Pro Micro, there is less "computer" stuff to handle and yet plenty to learn. My biggest hang-up at this stage was a bad USB cable! I won't talk about how many hours I lost thinking the drivers would not install when all I needed to do was switch to a new cable, and they magically installed themselves! I am constantly being reminded of the basics of troubleshooting 101.

The building instructions get one through the basics of dealing with loading programs and compiling and running them with no need to learn specifics of code or libraries. However, the idea is that we, primarily uninitiated, might be inspired to learn more to use the payload board for more and cooler experiments. I will openly admit this is a weak area for me, but learning new things is what the Cubesat Simulator is all about. Note: when you save a bit of code, don't think you're going to be smart and put the file where you think it should go. It needs to go right in the main Arduino directory, where the development tool saves it by default, so that the libraries and header files are all where they need to be for it to access them when it compiles and runs. (Don't ask me how I know this!) Once I learned that lesson, I found it immensely rewarding to see all the sensor fields in Foxtelem come to life with data for pressure, altitude, and temperature!

In the interim, while I was waiting for some part or another, I also decided to add the Pi camera option so my sim could transmit live slow-scan TV pictures. This feature had been so much fun at Dallas's last two Frontiers of Flight Moon Day events! People get a real kick from seeing the picture of themselves on screen as the ground station copies it with SSTV software! But be sure when you order the Pi camera to get the correct cable. The Pi Zero requires a smaller one than the standard one that comes with the camera,

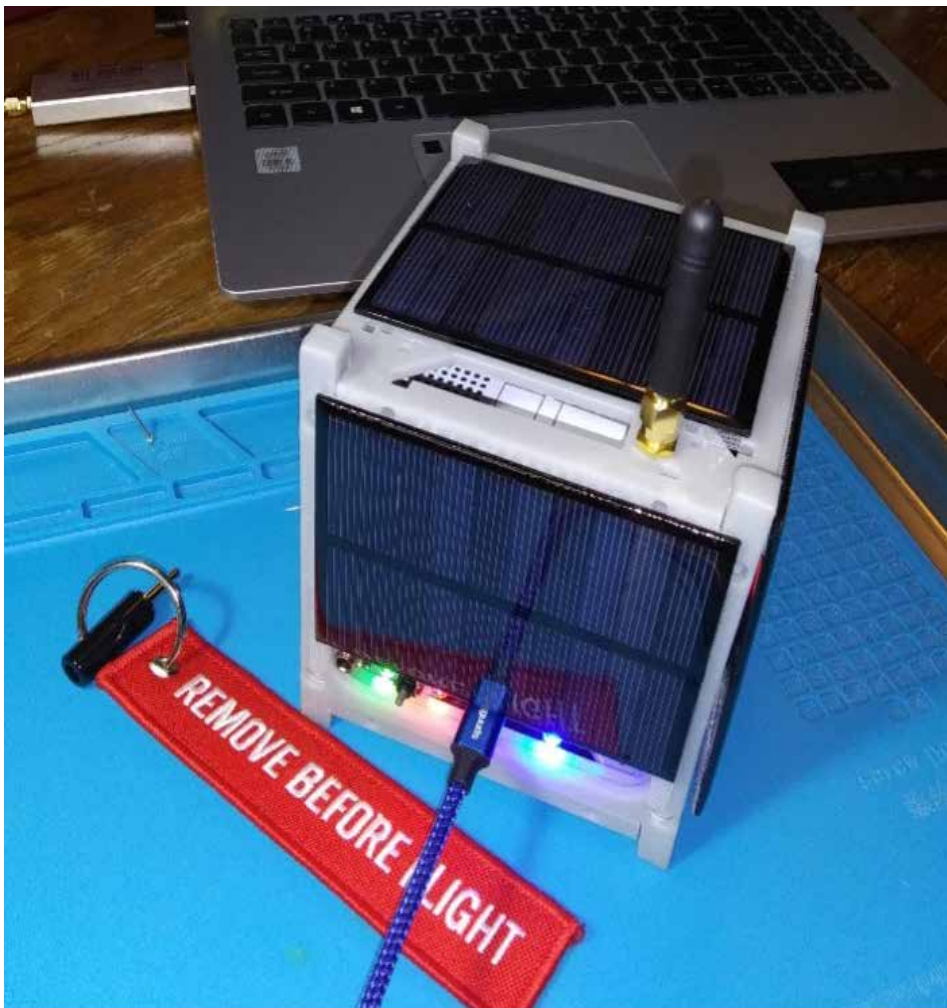

Figure 7 — The Cubesat Simulator completed and functioning





**Figure 8 — My team of alien advisors approving the final product.**

and, of course, the configuration for the side of the sim with the camera calls for two smaller solar panels instead of one large one. Unfortunately, due to ongoing supply issues, the ones on the BOM were nowhere to be found at the time, so I found similar ones on Amazon and had to improvise a little. And one starts to see how this whole project is a chain reaction where one thing leads to another and, before you know it, you have bought a bunch more parts!

The camera worked great, and all tests were successful, so it was time to stack everything and put it together. And here, at the very end, came the last little challenge. Being mostly ignorant in the 3-D printing world, I struggled to feel clear on the exact hardware needed to install the Pi camera board onto the 3-D printed frame piece. (When I ordered it, I assumed the installation hardware would come with the camera). Unfortunately, there was no source for these tiny screws and insets — which were mentioned in the instructions — on the BOM, and knowledge of exactly what parts to get seemed to be taken for granted. I did OK figuring it out, though the insets I found were not tapered, so I used the Dremel to ream out the 3-D printed holes a little, just enough to hammer the inserts in. Unfortunately, the lack of precision in my solution caused things not quite to line up, so the fourth tiny screw would not go in, but I think three is enough to keep the camera in place.

With this, the final stage was straightforward. Cutting up little strips of Velcro to affix the solar panels was the hardest part! I tested through the five Cubesat Sim transmit modes and found everything functioning, and all the solar panels and sensors were operational. In addition, my little herd of stuffed purple aliens seemed quite impressed with the result. My next objective is to explore the use of APRS, comprehend the payload board's finer points and its possibilities, and get a little turntable for the Cubesat Simulator to spin around!

Building the AMSAT Cubesat Simulator, with every misstep and all the long moments of waiting and contemplation, was an excellent chance to see the basics of the CubeSat function, more so than if everything had gone off without a hitch. The idea of eventually making — or possibly even designing — a real satellite with an uplink and a repeater and the thought that I could have the confidence to troubleshoot, repair, and understand its more advanced functions is most compelling. I still have a long way to go and plenty more to learn from this little simulator and my experiences teaching what I have learned from it. I hope, in the future, to contribute to the AMSAT Cubesat Simulator educational curriculum with accounts of my adventures and creative approach. I also hope this article is a start in that direction and that other new builders and aspiring engineers find it helpful right here in the present. 🌐

## Building AMSAT CubeSatSims in the Classroom: Experiences with Freshman Engineering Students

**Alan Johnston, Ph.D., KU2Y**  
**V.P. Educational Relations, AMSAT**  
**Associate Teaching Professor,**  
**Villanova University**  
**ku2y@arri.net**

**Edward Char**  
**Professor of the Practice,**  
**Villanova University**  
**edward.char@villanova.edu**

**A**bstract — The AMSAT CubeSatSim is a small, low-cost spacecraft simulator that serves as a tool for academic education, public demonstrations and theory and design disciplines. It can be used in a classroom, lab or training setting to introduce the basics of satellite operations, or it can be used to teach STEM (Science, Technology, Engineering, Math) exercises. This article is about a seven-week mini project at Villanova University in the spring of 2022 in which freshman electrical and computer engineering students built six CubeSatSims in three classes. The class design, organization, and outcomes are discussed in this article.

### CubeSatSim Overview

A CubeSat is a nanosatellite designed for low-cost educational space missions, defined by the CubeSat Design Specification (CDS) [www.cubesat.org](http://www.cubesat.org). The AMSAT CubeSatSim, the CubeSat Simulator, shown in Figure 1, is a Raspberry Pi Zero-based, 3D printed, functional model of a 1U form factor CubeSat. It is designed to act, as reasonably as possible, as one flying in Low Earth Orbit (LEO) to demystify how satellites work. The construction plans and software are fully open-sourced, and information about building one is available at [cubesatsim.org](http://cubesatsim.org). Like real LEO satellites, this simulator is self-powered through onboard rechargeable batteries and solar panels. In addition, it transmits telemetry wireless on the ham radio UHF band in various formats. For details on the design and construction of the simulator, see our article in the March/April 2020 issue of *The AMSAT Journal* ([cubesatsim.org/content/CubeSatSimPaper5.pdf](http://cubesatsim.org/content/CubeSatSimPaper5.pdf)). There is also a lot



of good information on the CubeSatSim Project page [cubesatsim.org](http://cubesatsim.org).

For a history of the AMSAT CubeSat Simulator, see the article “A Year with the AMSAT CubeSat Simulator: 12 Months in the Classroom and Lab” in the AMSAT 2019 Space Symposium.

A high-level block diagram of the CubeSatSim design is shown in Figure 2.

The four boards of the CubeSatSim are shown in Figure 3.

A ground station is used to receive the radio telemetry and decode and display the information, such as solar panel and battery voltages, currents, temperatures, camera

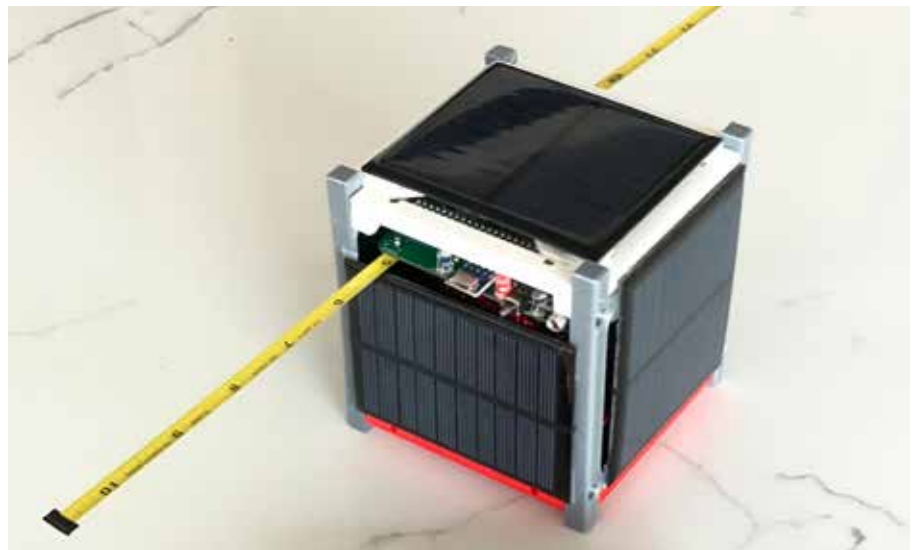

Figure 1 — The AMSAT CubeSatSim has low-cost 5.5V solar panels, a 3D printed frame, and a tape measure dipole antenna.

## CubeSatSim Block Diagram v1

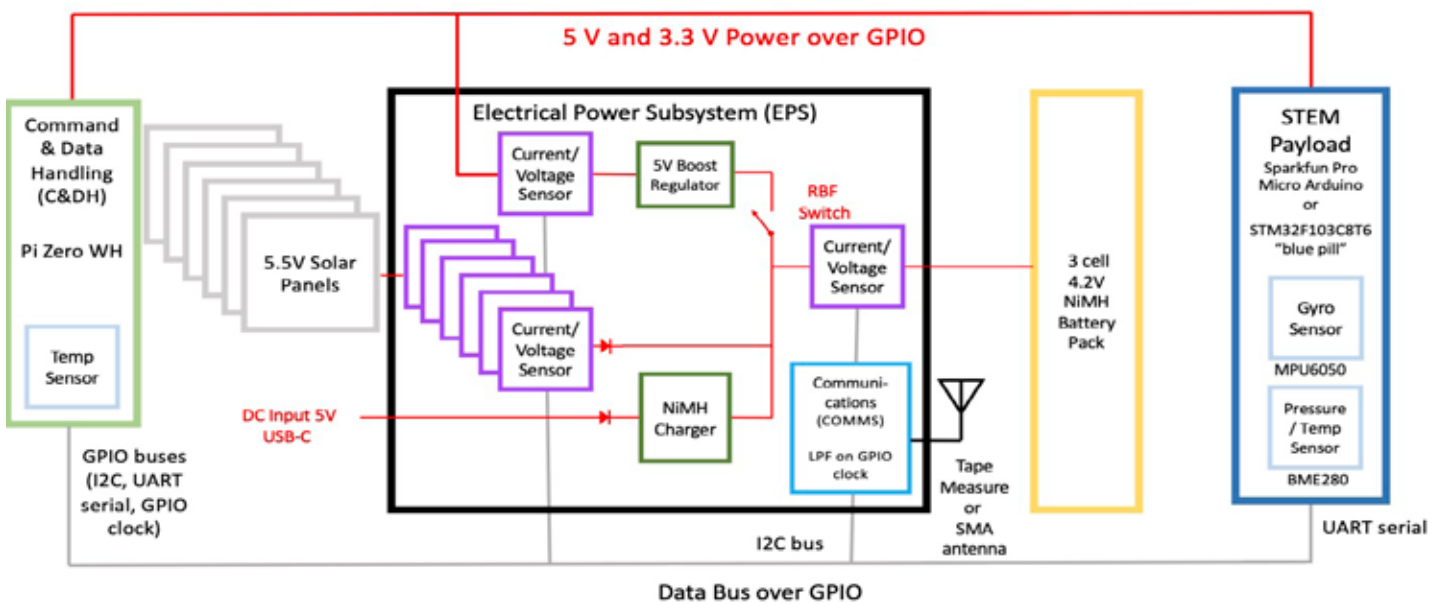

Figure 2 — Block Diagram of the CubeSatSim.



Figure 3 — Boards of the CubeSatSim. From left to right, the Pi Zero WH with Pi Camera, Mainboard, Battery board, and STEM Payload board with Sparkfun Pro Micro microcontroller.

images, and sensor and gyro data. A low-cost (\$35) RTL-SDR software defined radio (SDR) USB dongle is used along with open-source software. The software is the same software the AMSAT and other satellite builders use to track and monitor on-orbit spacecraft. The software can run on a PC or a Raspberry Pi 3B or 4B.

This article is about how CubeSatSims were built in a classroom by students organized into subteams that built and tested specific parts of the simulator.

### Course Overview

The course was an introductory electrical and computer engineering course taken by students in the second semester of their four-year degree program. The course aims to give students some hands-on experience doing engineering work in a project setting.

Here are the specific goals of the mini project as presented to the students:

- Learn about CubeSats and satellite technology
- Understand the role of radio and telemetry in satellite operation and how to interpret telemetry
- Gain experience working in small teams on different aspects of a project
- Get experience giving a presentation, writing a short report, and sharing information using a Wiki
- Have some fun!

Earlier in the course, students had completed a two-week soldering project in which they built and tested a flashing and buzzing PCB board. Nearly all students had never soldered before, so the CubeSatSim was their second soldering project.

The CubeSatSims were built as part of a CubeSat Mini Project which also included the following activities:

- Researching CubeSats and launch vehicles;
- Building tape measure Yagi-Uda antennas and listening to the ISS and satellites on passes over campus using laptops and RTL-SDR dongles; and
- Giving a short impromptu "Space Hot Topics" presentation.

In previous semesters, we also did a SatNOGS activity where students selected satellite passes for observations in one class, then listened to the results and vetted them

## Subsystems

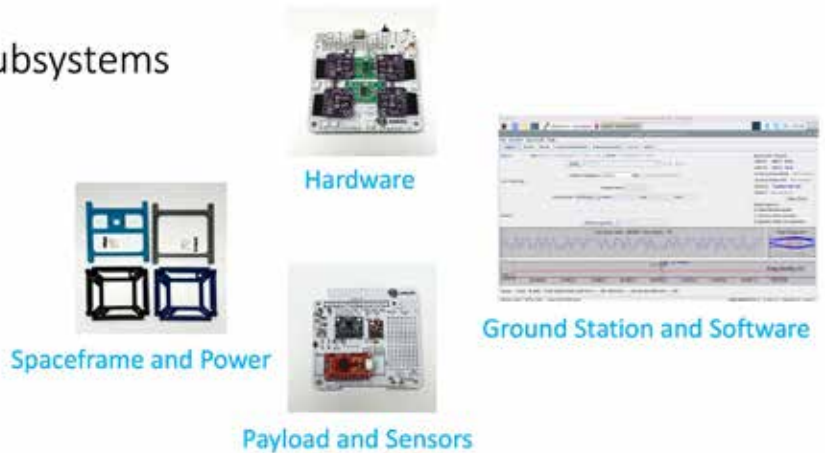

Figure 4 — Four Subsystems of the CubeSatSim.

in another class. This activity is described in Appendix A.

### Subteams

There were three classes in total, and the class size ranged from 18 to 30 students. Each class was divided into two groups, and each group built a CubeSatSim. Students in each group were divided into subteams responsible for a particular subsystem, as shown in Figure 4, a slide presented to students.

Here are the details of the subteams and their responsibilities:

- Spaceframe and Power - 3D printing the frame, soldering and testing the solar panels, building and mounting the antenna;
- Hardware - soldering and testing the Mainboard;
- Payload Sensor - soldering and testing the STEM Payload Board, using the Arduino IDE to install the software for the Pro Micro microcontroller;
- Ground Station and Software - installing the software for the Raspberry Pi Zero, configuring it for testing, installing and using ground station software on PCs and Raspberry Pis.

Students had a chance to indicate their preferred subteam. Approximately half of the students expressed a preference, so everyone's first preference was satisfied.

As the size of classes varied, and we were building two CubeSatSims per class, the size of the subteams ranged from 2 to 4 students per team.

### Steps in Building a CubeSatSim

As listed in the Wiki build instructions

[CubeSatSim/wiki](#), there are nine steps to building a CubeSatSim.

For these nine steps, the primary subteam responsible for each step is listed after each one:

1. [Build the Mainboard Part 1](#) (Hardware);
2. [Install the Software](#) (Ground Station and Software);
3. [Build a Ground Station](#) (Ground Station);
4. [Continue Building the Mainboard Part 2](#) (Hardware);
5. [Build the Battery board](#) (Spaceframe and Power);
6. [Assemble the Solar Panels and Frame](#) (Spaceframe and Power/ Ground Station and Software);
7. [Finish the Mainboard Part 3](#) (Hardware);
8. [Build the STEM Payload board](#) (Payload and Sensor); and
9. [Put the Board Stack together and mount it in the Frame](#) (All).

This is also the recommended order if a single person or small group is building a CubeSatSim. However, when the build is being done across subteams, the work breakdown schedule is shown in Table 1, based on a 75-minute class build period.

The numbers for each item in the Table refer to the step number in the CubeSatSim Wiki instructions. For example, "4.2 Main Board 2 Build" is Step 4 section 2 in the Wiki, called "Main Board 2".

Some steps have no dependencies; for example, the Mainboard, Battery Board, and STEM Payload board can all be built independently and the Pi Zero software



Build Session	Hardware Subsystem	Spaceframe and Power Subsystem	Ground Station and Software Subsystem	Payload and Sensors Subsystem
1	1. Main Board 1 Build	6.2 3D printing frame	2. Software Install	Arduino IDE install and Blink Test (Blink test part of 8.2 STEM Payload Board)
2	1. Main Board 1 Build	5. Battery Board Build	3.2 PC Ground Station	8.1 STEM Payload Board Build
3	4.1 Main Board 2 Testing 4.2 Main Board 2 Build	6.1 Solar panels	3.1 Raspberry Pi Ground Station	8.1 STEM Payload Board Build
4	4.2 Main Board 2 Build	6.1 Solar panels	6.3 Pi Camera Install	8.2 STEM Payload Board Testing
5	7.1 Testing Main Board 3 7.2 Main Board 3 Build	9.1 Antenna Install	Simulated Telemetry Analysis	Sensor Verification on PC and on Telemetry
6	7.3 Flat Sat Testing 9.2 Stacking Boards	7.3 Flat Sat Testing 9.2 Stacking Boards	7.3 Flat Sat Testing 9.2 Stacking Boards	7.3 Flat Sat Testing 9.2 Stacking Boards
7	9.3 Install in Frame	9.3 Install in Frame	9.3 Install in Frame	9.3 Install in Frame

**Table 1 — Build Schedule by Subteam.**

installed. However, there are dependencies in testing that this breakdown tries to address, such as:

1. The testing of the Mainboard in Step 4.1 requires the Pi Zero with the software installed;
2. The testing of the INA219 boards in Step 4.2 requires the Pi Zero with the software installed;
3. The testing of the Mainboard in Step 7.1 requires a Ground Station, Battery board, Pi Zero with software installed, and a solar panel and connector;
4. The testing of the STEM Payload board in Step 7.2 Complete Payload Test requires a Pi Zero and a Ground Station;
5. The Flat Sat testing in Step 7.3 requires a Ground Station, Battery board, Pi Zero with software installed, and a solar panel and connector;
6. The Stacking Boards step 9.2 requires all three boards and the Pi Zero; and
7. The Installation of the Boards in the frame step 9.3 requires all boards and the frame.

Each subteam had a Wiki page to record their progress and identify issues and problems. In addition, the instructors used the Wiki pages to communicate with the subteams. Before each class, instructors posted guidance and other information to students, who were advised to read their Wiki pages at the start of class. With 15 minutes remaining in each class, students were reminded to fill in their Wiki pages with their status updates.

Each classroom also had:

- A complete CubeSatSim for reference. The Ground Station and Software teams used it during the initial weeks to generate radio signals and learn how to operate the CubeSatSim.
- A CubeSatSim Lite board with a stacking GPIO header installed. It was plugged into the Pi Zero WH by the Ground Station and Software teams to test radio transmission during the early sessions. In addition, the STEM Payload board was plugged on top to test the STEM Payload Board.

- A complete Raspberry Pi ground station with a touch screen, speakers, and a wireless mouse provided decoding of all telemetry modes.

Here is a list of the tools which were provided in each classroom:

- Soldering iron and lead-free solder (to solder the components on the boards);
- Metal curls solder tip cleaning station (to clean the soldering iron tip);
- Safety glasses (to protect eyes while soldering or trimming leads);
- Small Phillips screwdriver (for standoff hardware);
- Small flathead screwdriver (for frame hardware);
- Needle nose pliers (to bend leads and hold parts);
- Heat gun (for heat shrink tubing);
- Side cutters (to trim leads);
- Drill and drill bits, sandpaper or emery cloth (for making the dipole or monopole antenna and Remove Before Flight plug);
- Liquid flux (to solder SMA connector);
- Various micro USB and USB-C cables; and
- Micro SD card USB writer to flash the micro SD card for the Pi Zero W.

### Kits

The online CubeSatSim BOM (Bill of Materials) has a sheet "By Step" (click at the bottom - see Figure 5) which lists the parts needed for each step in order ([cubesatsim.org/bom](http://cubesatsim.org/bom)). If you have a Google account, you can make a copy of this spreadsheet ("File" then "Make a Copy") and check off each part as you install it.

We started with CubeSatSim PCB Sets from the AMSAT Store [www.amsat.org/product/amsat-cubesatsim-pcb/](http://www.amsat.org/product/amsat-cubesatsim-pcb/) as shown in Figure 6, which has the Low Pass Filter and USB-C surface mount components already installed, so only through-hole soldering is required.

We ordered Pi Zero W kits which included a blank 64 GB SD Card (a 16 GB is the minimum necessary), power supply, HDMI and USB adapters, and GPIO pin headers. The instructor soldered the pin headers onto the Pi and tested them. The Pi Zero WHs should be reusable for future classes



and projects.

We ordered Sparkfun Pro Micro 3.3 V microcontrollers, and the instructor soldered the pin headers. The Pro Micros should be reusable for future classes and projects.

We used brass standoffs as they are stronger than nylon ones.

Students used PLA 3D printers available on campus to print the frame after downloading the STL files from the internet. No CAD work was required.

The BOM spreadsheet has a "By Step" view (sheet) that lists the parts needed for each step and a photo of each part to aid

identification. Parts for each step were put in an anti-static bag and labeled with the Step number. The anti-static bags (approximately 9" x 8") were large enough for the built parts also to be stored in them. A box for each group contained the nine bags for a complete CubeSatSim. For example, the parts list for Step 7 is shown in Figure 7.

Note that parts that install on the PCB are labeled as Top or Bottom depending on which side of the PCB they are installed on. The PCB also has a solder mask on the part side of most components, making it harder to install and solder the components on the wrong side. An example parts kit for Step 7

is shown in Figure 8.

In each class, one kit contained the tape measure antenna, and one kit included the SMA antenna.

## Results

The results of the class CubeSatSim build were encouraging. All but one group completed their tasks and had working boards. Photos of students building and testing the CubeSatSims are in Figures 9 - 12.

## Using the CubeSatSim

The mini-project was done at the end of the

Ref	Item	Qty	Cost	Total	Source	Source URL	Alternate
U10	5V boost regulator 500 mA	1	\$4.00	\$4.00	eBay	<a href="https://www.ebay.com/sch/i/f">https://www.ebay.com/sch/i/f</a>	<a href="https://www">https://www</a>
U9	NIMH CN3085 3s charger	1	\$2.99	\$2.99	eBay	<a href="https://www.amazon.com/Vil">https://www.amazon.com/Vil</a>	<a href="https://www">https://www</a>
	1x14 male breakaway header	1	\$0.47	\$0.47	Digikey	<a href="https://www.digikey.com/en/">https://www.digikey.com/en/</a>	
	USB-C charger with Micro USB adapter	1	\$10.99	\$10.99	Amazon	<a href="https://www.amazon.com/">https://www.amazon.com/</a>	
X1	5C1464-ND 3.50mm Headphone Phone Jack S	1	\$2.10	\$2.10	Digikey	<a href="https://www.digikey.com/g">https://www.digikey.com/g</a>	<a href="https://www">https://www</a>
D1-D7	Diode 1N5817RLG D1, D2, D3, D4, D5, D6, D7	7	\$0.40	\$2.80	Digikey	<a href="https://www.digikey.com/g">https://www.digikey.com/g</a>	<a href="https://es.s">https://es.s</a>
	Remove Before Flight Tag	1	\$8.00	\$8.00	Amazon	<a href="https://www.amazon.com/">https://www.amazon.com/</a>	<a href="https://www">https://www</a>

Figure 5 — CubeSatSim online Bill of Materials spreadsheet [CubeSatSim.org/bom](http://cubesatsim.org/bom).

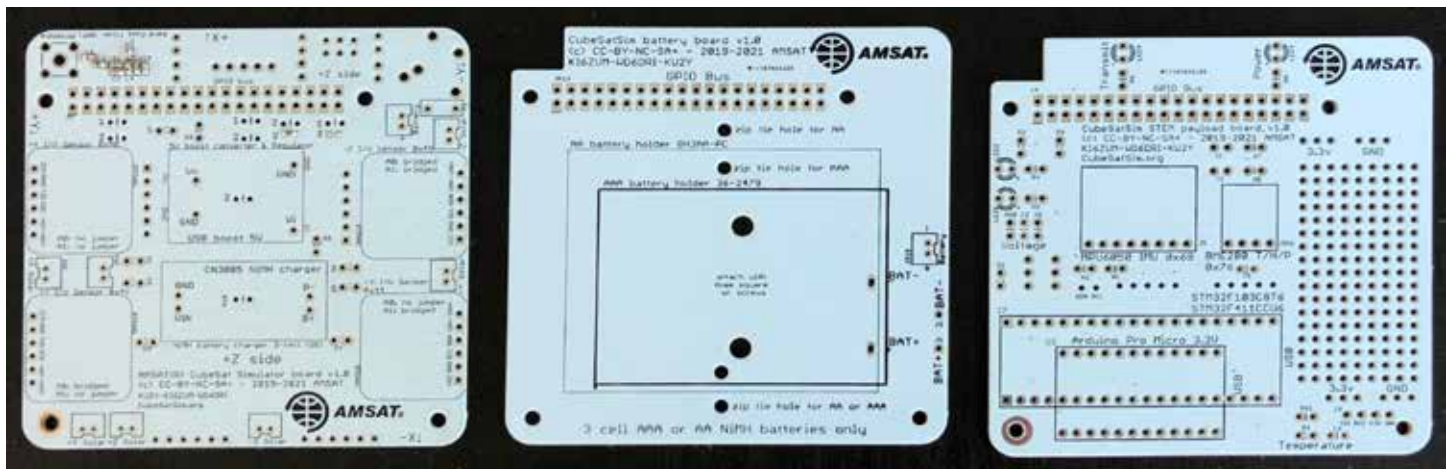

Figure 6 — Three blank PCB boards with SMD (Surface Mount Devices) already installed, available at the AMSAT







Ref	Item	Qty	Location	Image
U9	NiMH CN3085 3s charger	1	Top	
U10	5V boost regulator 500 mA	1	Top	
D8	5.1V 400mW Zener	1	Top	
F1	PTC resettable fuse, 1.2A	1	Top	
X1	1/8" 3.5mm Plug Audio Jack Connector	1		

Figure 7 — Parts list for Step 7. Main Board 3 in the BOM in By Steps view.



Figure 8 — Parts kit for Step 7.

semester, so there was no opportunity for the schedule to slip. As a result, we, unfortunately, had little time to use the built CubeSatSims. However, we did have one session where the students received telemetry and interpreted it.

One working CubeSatSim was placed on a turntable in front of the lamp and put on a cart. After "launching" it in front of the class, it was wheeled into the hallway, where it couldn't be seen.

Students ran FoxTelem on their laptops, received radio signals, and interpreted the results.

The details of this class activity are described in Appendix B.

### Lessons Learned

As this was the first time building the CubeSatSim with the v1 hardware, we learned quite a bit during the project. For example, we

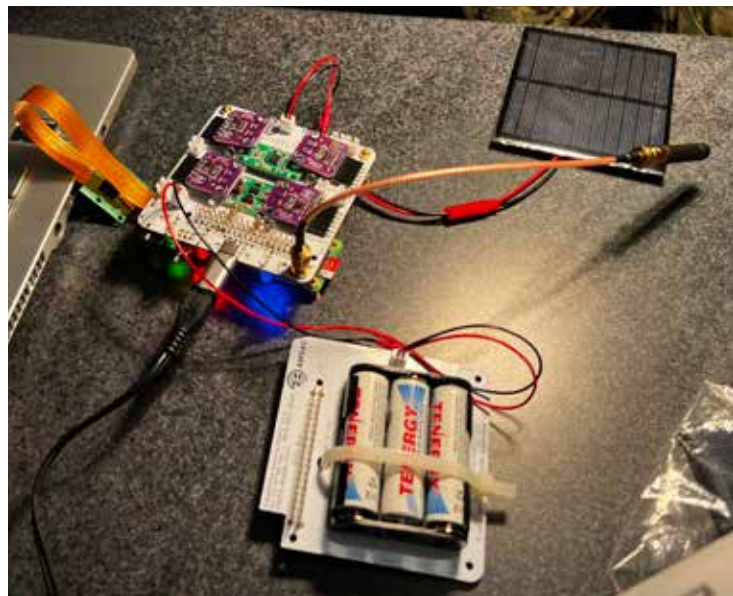

Figure 9 — Flat Sat testing of the CubeSatSim.

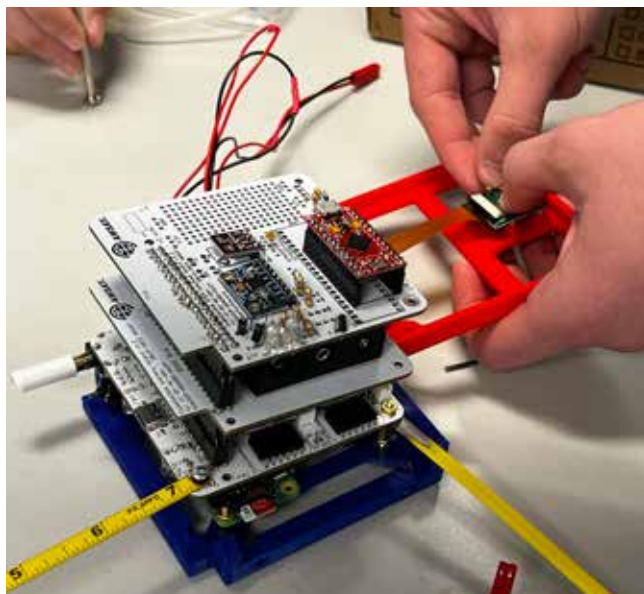

Figure 10 — Mounting the camera in the frame.

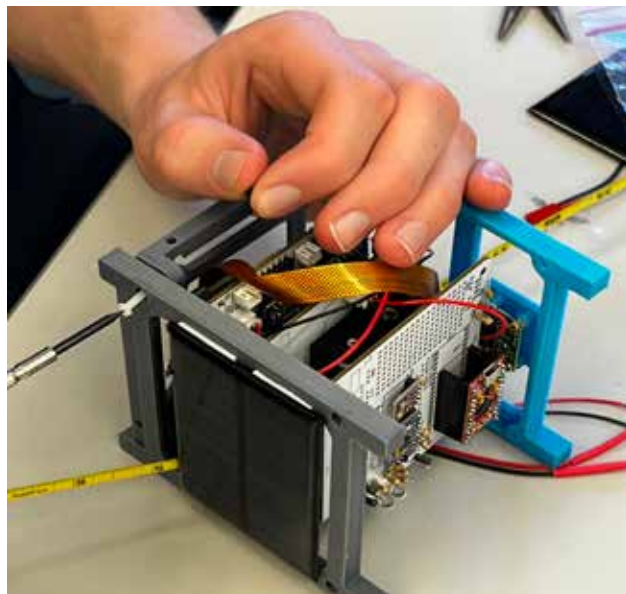

Figure 11 — Putting the frame together.



**Figure 12 — Cart with four completed CubeSatSims.**

realized we needed more time for FlatSat testing and Stacking steps. So we completed the testing and stacking, but it was rushed, and we left out mounting hardware and other non-essential parts.

A few teams could have benefited from extra “catchup” sessions to help them finish their board. The Payload and Sensors teams finished early, so this subteam needs some additional tasks.

Teams of 4 weren't ideal, resulting in downtime for some team members. Teams of 2 seemed ideal, with both team members fully engaged. Instead of having teams of 4, an additional CubeSatSim should be built in the class to keep the team sizes as small as possible.

Students wanted to edit Wiki pages simultaneously, but only one could at a time. One possible solution is to break Wiki pages into parts so they could edit each part individually without conflict.

CubeSatSims powered up in the same classroom interfered with each other, and sometimes students were confused by this. A script could be written to change the

transmit frequency of one. We also were able to pick up weak signals from CubeSatSims in another classroom that was occurring at the same time.

We had many problems with the purple INA219 boards, and testing them was tedious. Therefore, we now recommend the blue INA219 boards, which are easier to find and do not have all the failures.

Students wanted to learn more about other subteams. So, in the future, we will add a week of cross-training, where one subteam will train another subteam on their subsystem.

One team did soldering on a Battery Board with the batteries installed - they had already installed the zip tie and didn't want to cut it and replace it. During this soldering, they accidentally bridged the + and - pins, and the PCB trace glowed red like a toaster element. The instructor saw (and smelled!) it and quickly unsoldered the bridge. The batteries and PCB still worked. This is a good reminder of why we use NiMH batteries instead of Lithium batteries!

The BME sensor was installed upside down

on two Payload boards. The PCB has a circle on the silkscreen to help prevent this.

“Unbridging” pins with a soldering iron is an essential skill many have developed. Students were reminded to have an instructor inspect a board before doing any testing or applying power.

One group accidentally switched the blue and green LEDs. So we left them that way.

One group had trouble at the start with putting the wrong resistors and the wrong polarity of the LEDs. Eventually, they were given a new PCB and just started again. Always have extra parts and PCBs in case this happens.

One team did a perfect job on their Payload board until the last step when they soldered the GPIO connector on the wrong side of the PCB. Unsoldering it would have been difficult (all 40 pins!), so the instructor tacked another GPIO connector on the correct side and had the students solder the remaining pins. This could be useful for prototyping, as it would allow jumper wires to be connected.

## Conclusion

The CubeSat Mini Project was a success for freshman electrical and computer engineering students. Students worked in teams, built a subsystem, and then participated in integration and system testing. While not every group completed their CubeSat build, all the groups gained some hands-on experience in a realistic engineering project. The six CubeSatSims built will be used for demonstrations, capstone projects, and as AMSAT loaners.

## Participating in the CubeSatSim Project

You can participate in the AMSAT CubeSatSim Project! One way to do that is to include documenting your CubeSat Simulator build and testing on social media. Also, offer to demonstrate your CubeSat Simulator to local schools, your ham club, Makerspace or Hackerspace gatherings, or other STEM events.

The official CubeSatSim Project Twitter account is [@CubeSatSim](#), and we use the hashtag [#CubeSatSim](#) to highlight our activities.

## Acknowledgments

Thanks to the Villanova University Electrical and Computer Engineering Department, which funded the parts and tools for the project.



Thanks to the members and board of directors of AMSAT for their financial support of the CubeSatSim project. Also, thanks to the many volunteers and team members who have contributed, especially Jim McLaughlin, KI6ZUM, David White, WD6DRI, Paul Graveline, K1YUB, Fredric Raab, KK6NOW, Mark Samis, KD2XS, Michael Spohn, N1SPW, Lindsay White, KI6LZN, Randy Standke, KQ6RS, and Pat Kilroy, N8PK.

This project would not be possible without many open source hardware and software projects.

## Appendix A - CubeSat SatNOGS activity

### Satellite Observation Scheduling Activity

**General Directions:** You will work individually on this activity. In the first class period, you will choose a satellite passing over Villanova in the next 24 hours. Then, you will research the expected radio signal from that satellite. The satellite observation will be scheduled on the Villanova University CubeSat Club SatNOGS (Satellite Networked Open Ground Station). In the second class period, you will view the observation of your satellite and determine if the satellite was transmitting a signal over Villanova.

We will be scheduling observations of satellites on the Villanova University SatNOGS station, located on the roof of

Tolentine Hall. Here is the link to access the station: [network.satnogs.org/stations/1159/](http://network.satnogs.org/stations/1159/).

In Figure 13, note that all times on SatNOGS are in UTC (which stands for Coordinated Universal Time (why?), the time formerly known as Greenwich Mean Time or GMT, also known as Zulu time). You can see the current UTC in the top right of the website, circled in the image.

### 1. Choose a Satellite Pass (10 minutes)

To see passes of satellites over Villanova that this satellite ground station can receive, click on the "Calculate Future Passes" button at the bottom left of the window (Figure 13). The website will run calculations based on the current satellites tracked by SatNOGS and the ground station location and display a lengthy listing of satellites passing over in the next 24 hours. Note that your screen will show different satellites depending on when you click on the button:

In Figure 14, the key information in each row is circled and is:

- Name: The NORAD ID and name of the satellite. In this example, 40908 and Lilacsat 2
- Success Rate: A graphical indication of the ratio of Successful Observations (Green) and Bad Observations (Red).

Sometimes you might also see Unvetted Observations (Yellow), which haven't been classified yet. If you mouse over the green part, you get the Success Rate in percentage, in this case a low 27%

- AOS (Acquisition of Signal) Time: The time in UTC when the satellite will be over the horizon and a signal might be received from the satellite.
- Maximum Elevation: The highest elevation in degrees during the pass, 15 degrees.

Based on this information, pick a satellite to schedule an observation. Here are some guidelines:

- You will be given a time range in UTC for choosing your pass. This will allow the observation to be scheduled and avoid conflicts with other classes.
- For a better chance of getting a Successful Observation, pick a pass where the Maximum Elevation is more than 25 degrees.
- A satellite with a higher Success Rate might be more likely to give a successful observation, so you might want to choose one greater than 50%. On the other hand, if you get a successful observation of a satellite with a low rate, that could be an exciting result.

The screenshot shows the SatNOGS website interface for station 1159. At the top right, the current time is displayed as 19:03 UTC, which is circled in red. Below the navigation bar, the station name '1159 - Villanova CubeSat Club W3YP' is shown. The station details include: Owner: w3yp, QTH Locator: FN20ha, Coordinates: 40.038°, -75.349°, Altitude: 12 m, Min Horizon: 10°, Antennas: VHF Lindenblad, Success Rate: 27% (represented by a green bar), Observations: 1495, Creation Date: 4 months, 1 week ago, Client version: 1.0, Online status: Last seen 0 minutes ago, and Uptime: 95 days, 21:44:14. A 'Calculate Future Passes' button is circled in red at the bottom left. A photo of the antenna setup is shown on the right. The footer includes copyright information for Libre Space Foundation and the CC BY-SA license.

Figure 13 — SatNOGS web page for station 1159.



Name	AOS	LOS	$\Delta$	Polar plot
40908-LILACSAT 2	21:01 2020-03-27	21:05 2020-03-27	$\pm 103^\circ$ $-15^\circ$ $\pm 30^\circ$	
25544-ISS	21:03 2020-03-27	21:10 2020-03-27	$\pm 218^\circ$ $+56^\circ$ $\pm 60^\circ$	
39444-FUNCUBE-1	21:09 2020-03-27	21:14 2020-03-27	$\pm 104^\circ$ $+16^\circ$ $\pm 27^\circ$	
39439-FIRST-MOVE	21:12 2020-03-27	21:19 2020-03-27	$\pm 116^\circ$ $+21^\circ$ $\pm 19^\circ$	

Figure 14 — Pass predictions in SatNOGS.

40908-LILACSAT 2

25544-ISS

39444-FUNCUBE-1

39439-FIRST-MOVE

40911-XW-28

### LILACSAT 2

[SatNOGS DB](#)

**LILACSAT 2 CAS-3H XW-2H**

NORAD ID: 40908

Success Rate: 67.54%

Observations: 10169 (6869, 89, 3201, 10)

CW Beacon

Observations: 251

FM Transponder

Observations: 1757

APRS Digipeater

Observations: 1816

GFSK Telemetry

Observations: 6344

Figure 15 — Satellite observations summary.



Enter your chosen satellite Name, Your Name, and AOS time in the class Google Doc. Make sure no one else in the class has selected the same satellite pass. You can choose the same satellite as long as it is a different pass (the AOS time is different).

We will discuss the chosen satellite passes in class, then move on to the next step.

## 2. Choose a Transmitter/Encoding for your satellite (10 mins)

A satellite can have several different transmitters, each sending signals using different encoding and modulation. For your chosen satellite, you will need to select one of the Encodings for your observation. To find out what transmitters/encodings are available for your satellite, click on your satellite name:

The list shows the different Transmitters for the satellite. In this case, it is CW Beacon (Morse Code), FM Transponder

(analog voice), APRS Digipeater (digital packet radio signals), and GFSK Telemetry (Gaussian Frequency Shift Keying digital telemetry). Your satellite might have a different list or only one. The success rate for each one is shown by the bars. For instance, in this example, the APRS Digipeater has a relatively low success rate, while the GFSK Telemetry has the highest number of observations and success rate.

Click on the “SatNOGS DB” button in the window to get the Transmitter Database.

Look at the map to see where your satellite is currently located. In this case, LilacSat 2 is off the coast of Argentina at the time of this screenshot.

Enter the Location in the Google Doc as the nearest country, body of water, or landmark.

You will see the same list of transmitters on the satellite as before, but with more information. The downlink is the frequency of the signal transmitted by the satellite

to earth. Some transmitters also have an uplink frequency. This is the frequency that amateur radio operators can transmit on to send signals to the satellite. Our satellite observations in this activity are signals received from the satellite, so we are only concerned about the downlink frequency.

The Villanova SatNOGS station has a VHF (Very High Frequency) Lindenblad antenna that can only receive signals from 135 MHz to 148 MHz. Therefore, you can only choose a transmitter with a downlink frequency range of 135 – 148 MHz. In this case, only one of the transmitters is in this range, the APRS digipeater at a frequency of 144.390 MHz. If there are multiple ones, then you have a choice.

Choose one that you are interested in with a high success rate and many observations (the previous window has the information). From the previous window, GFSK Telemetry has the highest success rate, but that transmitter

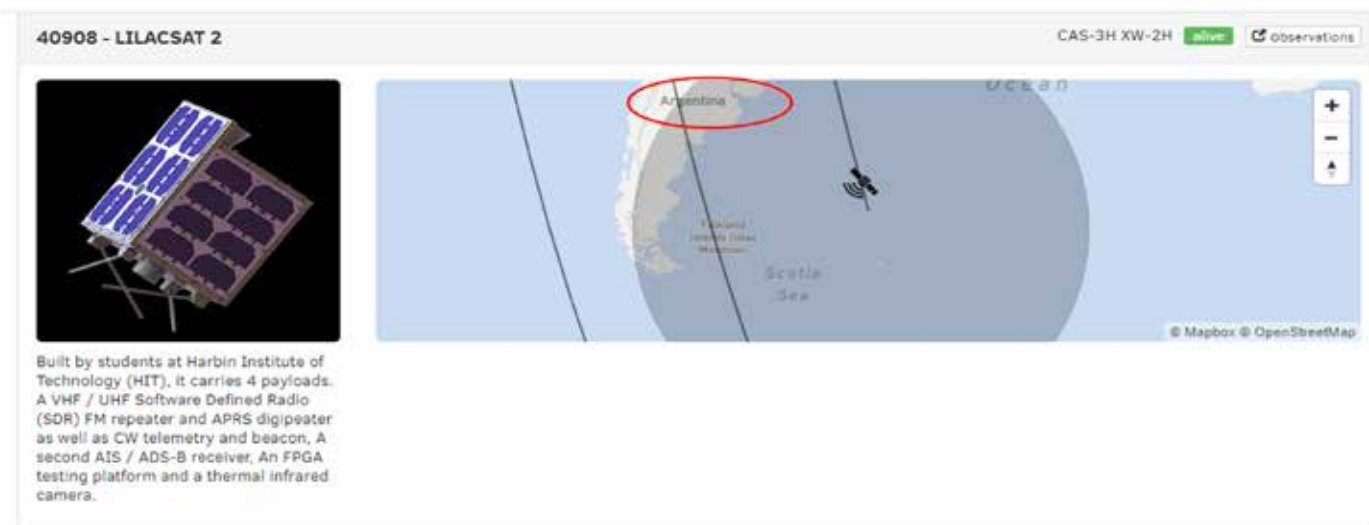

Figure 16 — SatNOGS database entry for a satellite.

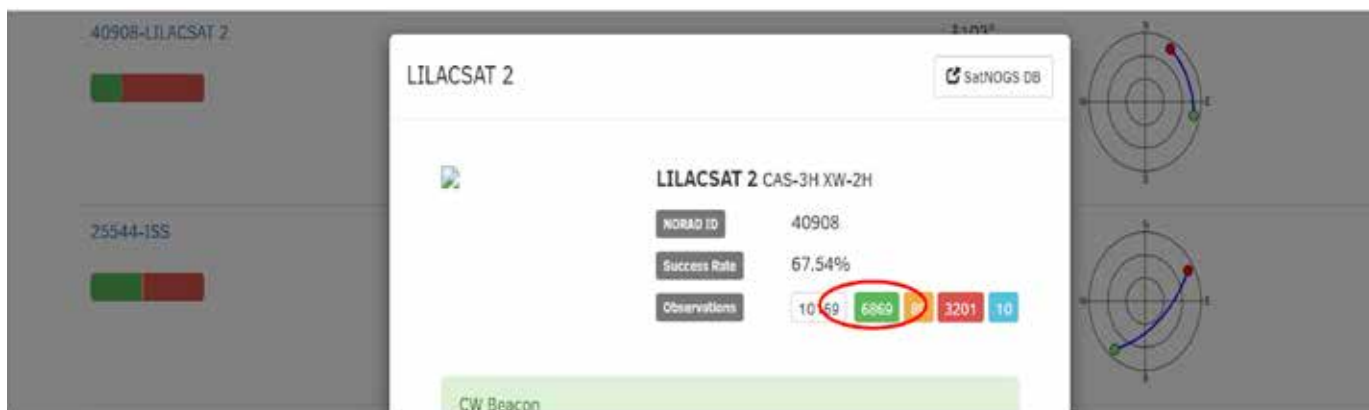

Figure 17 — Viewing successful observations of a satellite.

is at 437.225 MHz, which is in the UHF (Ultra High Frequency) band, outside the range of our antenna.

Enter your chosen Transmitter Name, Downlink Mode, and Downlink Frequency in the class Google Doc.

We will discuss the chosen transmitters in class before moving on to the next step.

### 3. Identify a Successful Observation of your satellite and Transmitter (10 mins)

You will search for a successful observation in a previous pass for your chosen satellite. Do this by clicking on your satellite name as in the previous step. Under Observations, there will be a number in a green box – click

on that button to open a list of Successful Observations.

In this list, the different Transmitters are listed as "Encodings." Multiple transmitters will be mixed in this list, so you need to look for Successful Observations (green) that list your chosen transmitter (Encoding). Right-click on a few to open them in a new tab and check to see if they are, in fact, good observations (some Bad observations are incorrectly classified as Good). For example, here is one Successful Observation is shown below.

The observation appears to be good because there is a signal in the middle of the waterfall (light green) that is a digital signal (a series

of lines). And the signals are roughly in a straight line (not curved), indicating that the signal matched the expected Doppler frequency shift.

Once you have found a Successful Observation, copy the link (URL) into the Google Doc.

### 4. Try to find a Successful Observation with Decoded Data (10 mins)

A successful observation with decoded data will have a number next to the observation in a list, such as this:

There will be a number in the Data tab on the actual observation page, such as the previous observation has "Data(1)". Click on the Data

## Observation #1917019

Timeframes are in UTC

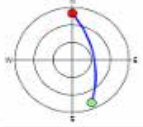
Satellite	40908 - LILACSAT 2
Station	1337 - Martin 9V1RM - UHF
Observer	Martin RATH
Status	Good
Transmitter	GFSK Telemetry
Frequency	437.225 MHz
Encoding	GFSK 4800
Timeframe	2020-03-24 10:19:26 2020-03-24 10:26:49
Rise	157.0°
Max	55.0°
Set	0.0°
Client Version	1.2
Metadata	{ 5 items }
Polar Plot	
Downloads	Audio Waterfall

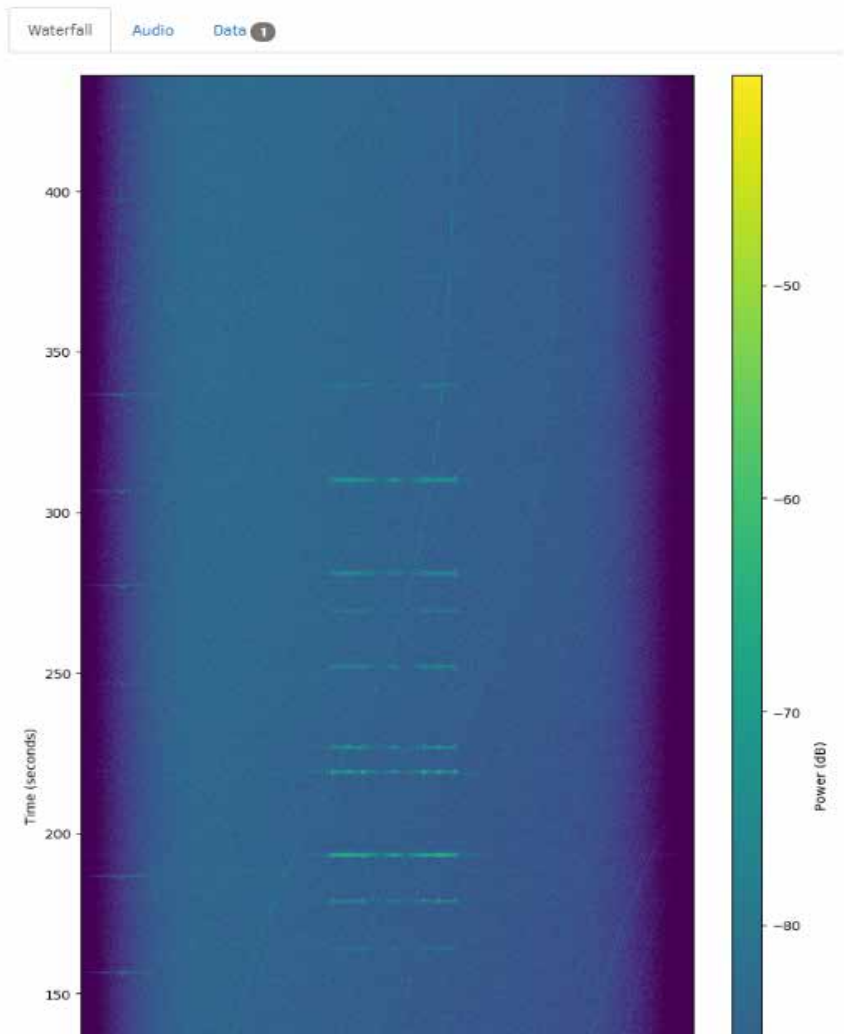

Figure 18 — A satellite observation.



1917019	LILACSAT 2	437.225 MHz	GFSK 4800	2020-03-24 10:19:26	 	Martin RATH	1337 - Martin 9V1RM - UHF
				2020-03-24 10:26:49			

Figure 19 — A successful observation with data.





- good? (3.8 V and above is good.)
- What is temperature? Is that good? (Room temperature is fine.)
- Are you getting any voltage or current from solar panels? Is that good? (Around 4V is good.)

Announce that we need to determine the rate of rotation using two different methods.

- A. Period of rotation using solar panels current peaks
  - B. Rotation rate from gyro/IMU
- Assign half the class to use method A and the other half to measure method B.

Write down the results of A and B on the board. Are they the same?

Announce that we need to determine the axis of rotation using two different methods.

- A. Solar panel X Y Z current peaks order and relative height
- B. Relative values of rotation of X Y Z from gyro/IMU

Write down the results of A and B on the board. Ask if they are the same.

Announce that in each orbit, the rotation can be different.

TA puts on the side (+X facing up) and changes turntable speed to H

What is the new axis of rotation?

What is the new rotation rate?

Announce it is another orbit later.

TA puts a 50 Ohm terminator in place of the antenna and puts a black post-it on +Z and -Z solar panels.

Ask if anything has changed.

- Answer: Yes, signal weaker.
- Answer: Yes, solar panel failures.

If time, have TA switch to SSTV (four blinks). Stop the turntable and put a cartoon alien photo in front of the camera.

Decode using speaker (a battery-powered speaker works well) and phone app (SSTV or Robot36). Also, show Raspberry Pi station, too. 📶

## 2022 AMSAT Field Day Results

**Bruce Paige, KK5DO**  
Member, Board of Directors  
Director, Contests and Awards

Once again, the ARRL has allowed stations at home operating on commercial power to participate fully in Field Day. AMSAT has done the same.

I was surprised that last year we had 22 stations participate with 29 satellites and this year we had 23 stations, with 23 satellites. The total QSO's between the two years was very close, 1144 in 2021 and 1184 in 2022.

As I do every year, the number of satellites is based upon their modes. SO-50 has one FM transponder and I count that as one satellite

	Phone	CW/Digital
AO-7	96	7
AO-91	17	
CAS-4A	95	1
CAS-4B	150	2
EO-88	13	
HO-113	48	3
FO-99	2	
ISS	14	
JO-97	76	3
PO-101	4	
RS-44	488	13
SO-50	10	
TO-108	13	
XW-2A	50	2
XW-2C	75	2

**Table 1.**

	2013	2014	2015	2016	2017	2018	2019	2020	2021	2022
Satellite	8	12	9	16	21	33	28	26	29	23
QSOs	443	305	316	424	728	945	746	1526	1144	1184
Stations	23	21	21	22	27	32	26	30	22	23
Points	613	357	386	448	778	995	848	1622	1223	1250

**Table 2.**

whereas AO-7 has two modes, SSB and CW and gets counted as two satellites.

The breakdown of satellite usage is shown in Table 1.

This year twenty-three stations participated in AMSAT Field Day (Table 2). They reported 1184 QSOs with a total of 1250 points, slightly higher than in 2021. There were 1151 Phone QSOs and 33 CW/Digital QSOs. Based on the numbers, it looks like RS-44 SSB was the busiest satellite again this year. Next up was CAS-4B followed by AO-7 and CAS-4A. The choice for CW contacts this year was RS-44 followed by AO-7.

This year we have three groups of winners: those operating Club Stations (#/A, E, F); those operating Battery/Home Emergency Power (1B/1E); and those operating Home Commercial Power (1D). All will receive their certificates at the symposium this year.

Here are the Club Station winners. Moving up to first place and holding on to its spot from last year is the Huntsville ARC, K4BFT, with 173 points. Tim, N8DEU, said that with 100-degree temperatures, it was really brutal at their field day site. They had interference on 70 cm from the club's HF and 6 m transmissions. After those were resolved, they found an issue with the feed harness for the UHF antenna. They were able to fix it after the sun started to set and the temperatures cooled. Not bad for losing almost the first half of field day with no 70 cm TX, fixing it and plugging on.

In second place, we have a newcomer to the recent standings, Grand Valley State University ARC, W8DC, with 169 points. A picture of their station appears in Photo 1. Their operators were Grace, KE8RJU, and Doug, K8DP, in Photo 2. In third place, dropping from second place last year, and not by many points, is Lafayette DX Association, W9LDX, with 167 points.

For operating at Home on Emergency Power, in first place, having placed second last year, is Scott, K5TA, with 105 points. Second place goes to Nick, M1DDD/P, with





**Photo 1.**

24 points. Nick was our only real DX entry this year. He was operating from the rear of his car with a LiFEPO4 battery and his Yaesu FT847 and Arrow antenna. Third place is Brook, N5DGK, with 3 points.

Our last group are those operating from home with commercial power. First place goes to Dave, W2GDJ, with 122 points. He also placed first last year. Second place goes to Terry, N6AJ, with 26 points. Yours truly took third place this year with 22 points. Had I kicked on the whole house generator, I could have placed third for Home on Emergency Power. What are the odds?

Scott, K5TA, although earning first place in the home station on emergency power, said that he “did not hit it 100% because



**Photo 2.**



**Photo 3.**

it was raining.” Dave, W2GDJ, was able to work Kjell as NA1SS, as did Danielle, KI5LQT, at the JSC ARC, N5T, station. They did not place this year, but it was a great learning experience for Danielle.

The Wilson ARC, WC4AR, also made a contact with the NA1SS and provided a nice photo of their operating stations in Photo 3. We had a few more stations work NA1SS, the Lafayette DX Association, W9LDX. They also sent along a few pictures. Photo 4 shows their antennas, station location and the generator (under its own awning). In Photo 5 we have Steve, N9IP, and Steve, W9TN, setting up the antenna. Photo 6 is David, N9KT, operating the station. The Loudoun ARG, K4LRG, and Philmore, W1EME, also got in on the fun working NA1SS.



**Photo 4.**

Although the San Lorenzo Valley ARC, K6MMM did not place this year, they did provide a great picture setting up their antennas in Photo 7. It was great to see the Idaho Mountain ARS, KX7ID, participating for their first time on satellite. Photo 8 offers a great picture of their field day site. The Loudoun ARG, K4LRG, passed along a few photos. Photo 9 shows their antenna setup and Photo 10 shows Steve, KS1G.

The Livonia ARC, K8UNS, was using an ICOM 9700 and an Arrow antenna with a S.A.T. for controlling Doppler. The AZ/EI was controlled this year by Mike, N8MR, and his arm. My favorite picture from all the submissions this year has to be one from the West Island ARC, VE2ARC, in Montreal. Photo 11, shot at night, is really cool.



**Photo 5.**

The Lake Monroe ARS, N4EH, experienced some severe thunderstorms in the area. A couple of hawks decided the antenna was a good resting stop, as shown in Photo 12. Photo 13, depicts Bayu, AF5D, operating from his home station.

We received a wonderful drone photo (photo 13) from the North Fulton ARL, K4JJ, of its site. Notice the elevation on the satellite antennas. Thanks to Daryl, K4RGK.

We had some good stories this year with some great pictures. If you did not send along field day photos, keep it in mind for next year.

As I say every year, for next year, remember, Murphy will somehow visit someone and spoil the day. Be prepared and have extra equipment, cables and connectors. Writing this article is always the most fun for me, and I hope you enjoyed reading it! 🌐



**Photo 6.**



Here are all entries received. In the case of a tie, call signs are listed alphabetically.

1	K4BFT	173	4A
2	W8DC	169	3A
3	W9LDX	167	1A
4	K4LRG	125	2A
5	W2GDJ	122	1D
6	K5TA	105	1B
7	K6MMM	49	1A
8	K4JJ	44	3A
9	K4UNS	36	4A
10	KX7ID	36	3A
11	N5T	35	9F
12	W5RRR	35	9F
13	N4EH	28	5A
14	N6AJ	26	1D
15	M1DDD/P	24	1B
16	KK5DO	22	1D
17	W1EME	18	1D
18	AF5D	11	1D
19	VE2ARC	11	1A
20	W3YP	9	1D
21	N5DGK	3	1B
22	N4QX	1	1E
23	WC4AR	1	3A



Photo 7.



Photo 8.



Photo 9.



Photo 10.



Photo 11.





Photo 12.



Photo 13.



Photo 14.

## MacDoppler

*The premier Satellite tracking and station automation application for the Macintosh*

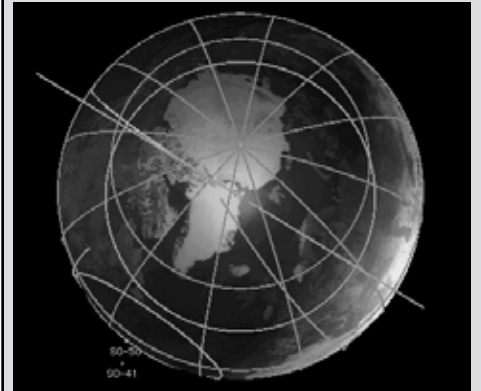

MacDoppler gives you a seat right in the heart of the Operations & Command Centre for every satellite in orbit, providing any level of station automation you need from assisted Doppler Tuning and Antenna Pointing right on up to a fully automated Satellite Gateway!

It will calculate the position and relative velocity of the satellites you are tracking and automatically adjust the Doppler shift on both transmit and receive as well as pointing your antennas with predictive dead spot crossing so that a pass is never interrupted.

A Universal Binary that runs native on Intel and M1 Macs and provides separate panels for the map (2D or 3D), the radio and rotor controls, a sorted table of upcoming satellite passes and a Horizon panel that graphs upcoming passes as a function of elevation over time.

**Now available from AMSAT at a special member discount donation!**

<https://www.amsat.org/product-category/software/>

**Dog Park Software Ltd.**  
www.dogparksoftware.com



# Join the 2022 AMSAT President's Club

## And Help Return Amateur Radio to High Earth Orbit!

AMSAT is excited about developing and launching the next generation of Greater Orbit Larger Footprint ("GOLF") satellites. AMSAT has an immediate need to raise funds to cover development, launch and related expenses to *Keep Amateur Radio in Space*. We have set a fundraising goal of \$125,000 to help keep AMSAT viable and effective in the competitive world of space communications.

**GOLF-TEE** (Technology Exploration Environment) is a rapid development satellite headed for LEO to fly and validate ADAC, deployable solar panel wing, radiation tolerant IHU, SDR and other technologies.

**GOLF-1** is planned as a "High LEO" mission with a STEM payload in the progression of GOLF satellites.

With your membership, AMSAT is pleased to recognize your generosity. All members receive:

**Commemorative Coin 2" with 4-color enamel accents and polished gold finish.**



**Full-color membership certificate**

**Embroidered 2.5" Iron-on AMSAT Logo Patch**



Higher tier members receive even more benefits! You can join with a single payment or with twelve affordable monthly payments with your credit card. For payment by check or electronic transfer, contact Frank Karnauskas, VP-Development at N1UW@AMSAT.org.

**Go to [AMSAT.org/donate](https://amsat.org/donate) and join today!**

Tier	Core	Bronze	Silver	Gold	Platinum	Titanium
<b>Annual Donation</b>	<b>\$120 +</b>	<b>\$300 +</b>	<b>\$600 +</b>	<b>\$1,200 +</b>	<b>\$2,400 +</b>	<b>\$4,800 +</b>
Journal Listing	X	X	X	X	X	X
Certificate	X	X	X	X	X	X
Coin	X	X	X	X	X	X
"RBF" Key Ring	X	X	X	X	X	X
Desk Plaque			X	X	X	X
TAPR/AMSAT Dinner @ Dayton				X	X	X
Symposium Admission					X	X
President's Symposium Lunch					X	X
Symposium VIP Recognition						X

Recognition items available for U.S. addresses only. For contributions from elsewhere please contact Frank Karnauskas, VP-Development at N1UW@AMSAT.org. AMSAT is a 501(c)3 corporation. Donations may be tax deductible. Check with your tax advisor. President's Club membership does not include AMSAT Annual Membership.





## With a 50-year Legacy of Success, AMSAT Volunteers ...

**Build satellites** that Keep Amateur Radio in Space!

**Promote space education** through ARISS and STEM-based initiatives.

**Manage satellites in orbit** and ensure they are available for public use.

**Create and maintain vital partnerships** with government, industry, educational institutions, and amateur radio organizations to foster space research and communication.

**Learn, teach and share innovations** and best practices in space communications with other radio operators, students, government and the public.

**Show and share their passion** for amateur radio in space everywhere they go!

**Will take amateur radio to the Moon, to Mars and to deep space ... with your help!**

**Go to <https://www.amsat.org/volunteer-for-amsat/> and help create AMSAT's future legacy!**

